

WHEN DISASSEMBLING ALUMINUM EXTRUSION, TIGHTEN ALL SETSCREWS AND LOCKS TO PREVENT LOSS DURING SHIPPING

visionary™ DESIGNS

Using Your Setup Instructions

The Visionary Designs Setup Instructions are created specifically for your configuration. They are laid out sequentially, including an exploded view of the entire display, and then a logical series of detailed steps to assemble the main structure and components. We encourage you to study the instructions **before** attempting to assemble your exhibit.

Each page reminds you to tighten the setscrews after disassembling your exhibit to prevent loss of the locks and setscrews (see below in RED). This is **VERY IMPORTANT**.

Cleaning and Packing Your Display

- 1) Use care when cleaning aluminum extrusion or acrylic inserts. Use only non-abrasive cleaners.
- 2) When cleaning laminate inserts or countertops, use mild cleansers and a soft material such as cotton.
- 3) Keep all display components away from extreme heat and long exposure to sunlight to avoid warping and fading.
- 4) Retain all packing material. It will make re-packing much easier and will reduce the likelihood of shipping damage.



The Tool

Most Visionary Designs exhibits can be assembled with the supplied Hex Key Tool. Occasionally, a flat head screwdriver may be required.



Typical Connection

Most horizontal extrusion connections have a patented expandable lock. This lock inserts into the groove of an opposing extrusion. Tightening the lock with the Hex Key Tool expands the lock and creates a strong positive connection.



Typical Connection (cont'd)

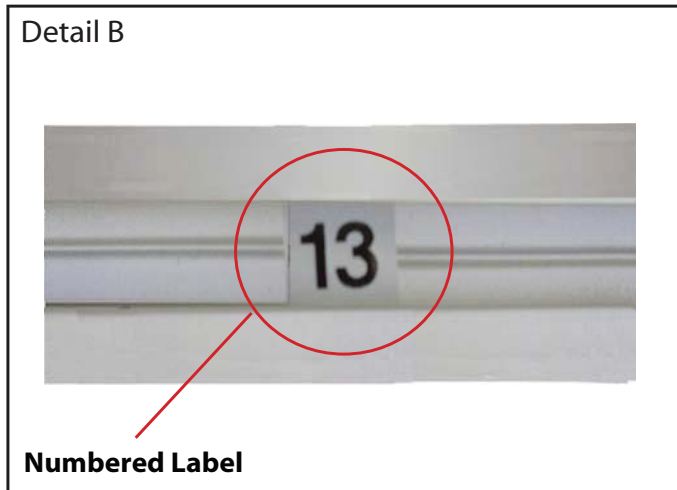

Detail B

Numbered Label

Each extrusion contains a numbered label which corresponds with setup instructions. The label is located within a groove of the extrusion (when possible). With Visionary Designs the labels contain Black numbers unless otherwise specified.



Detail C

Horizontal Inline Connection (remove only one setscrew)

Remove only (1) setscrew when disassembling. Replace setscrew in extrusion after assembling it. Before packing, replace setscrew in extrusion to avoid losing it.

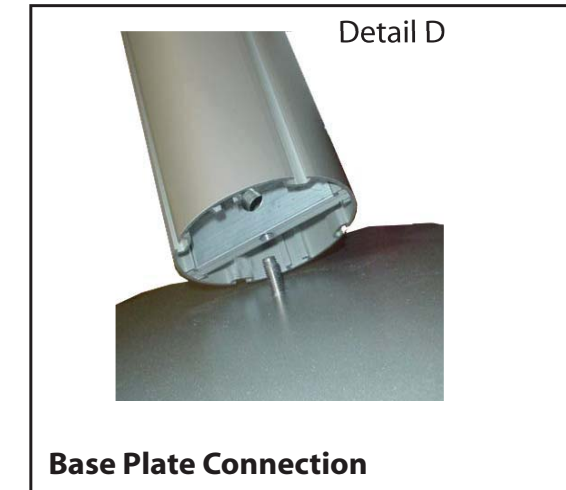

Detail D

Base Plate Connection

Attach base plate to round or square vertical extrusion using the bolt provided. Be careful not to strip the threads.

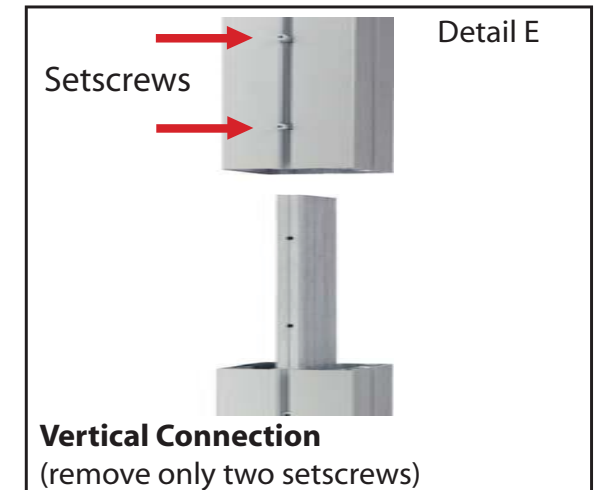

Detail E

Vertical Connection
(remove only two setscrews)

When vertical extrusions are packed in portable cases rather than crates or tubs, they must be broken down into smaller sections which then require assembly.

Remove only (2) setscrews when disassembling. Replace setscrews in extrusion after assembling it. Before packing, replace setscrews in extrusion to avoid losing them.

WHEN DISASSEMBLING ALUMINUM EXTRUSION, TIGHTEN ALL SETSCREWS AND LOCKS TO PREVENT LOSS DURING SHIPPING

Item	Quantity	Description
1	2	Oval Base Plate
2	2	48" Roud Vertical Extrusion
3	1	48" Roud Vertical Extrusion
4	2	48" Roud Vertical Extrusion
5	1	48" Roud Vertical Extrusion
6	1	45" Horizontal Extrusion
7	1	43.5" Curved Horizontal Extrusion
8	1	43.5" Curved Horizontal Extrusion

Steps:

- 1) Attach oval base plates [1] to 48" round vertical extrusion [2], refer to detail D on general info page.
- 2) Attach 48" round vertical extrusions [4] atop 48" round vertical extrusions [2 and 3].
- 3) Attach 48" round vertical extrusion [5] atop remaining 48" round vertical extrusion [2].
- 4) Attach 45" horizontal extrusion [6] bewtween vertical extrusions [2/5 and 3/4] as shown.
- 5) Connect 43.5" curved horizontal extrusions [7 to 8] form (1) 87" curved horizontal extrusion.
- 6) Attach 87" curved horizontal extrusion [7/8] between 48" round vertical extrusions [2/4 and 3/4].

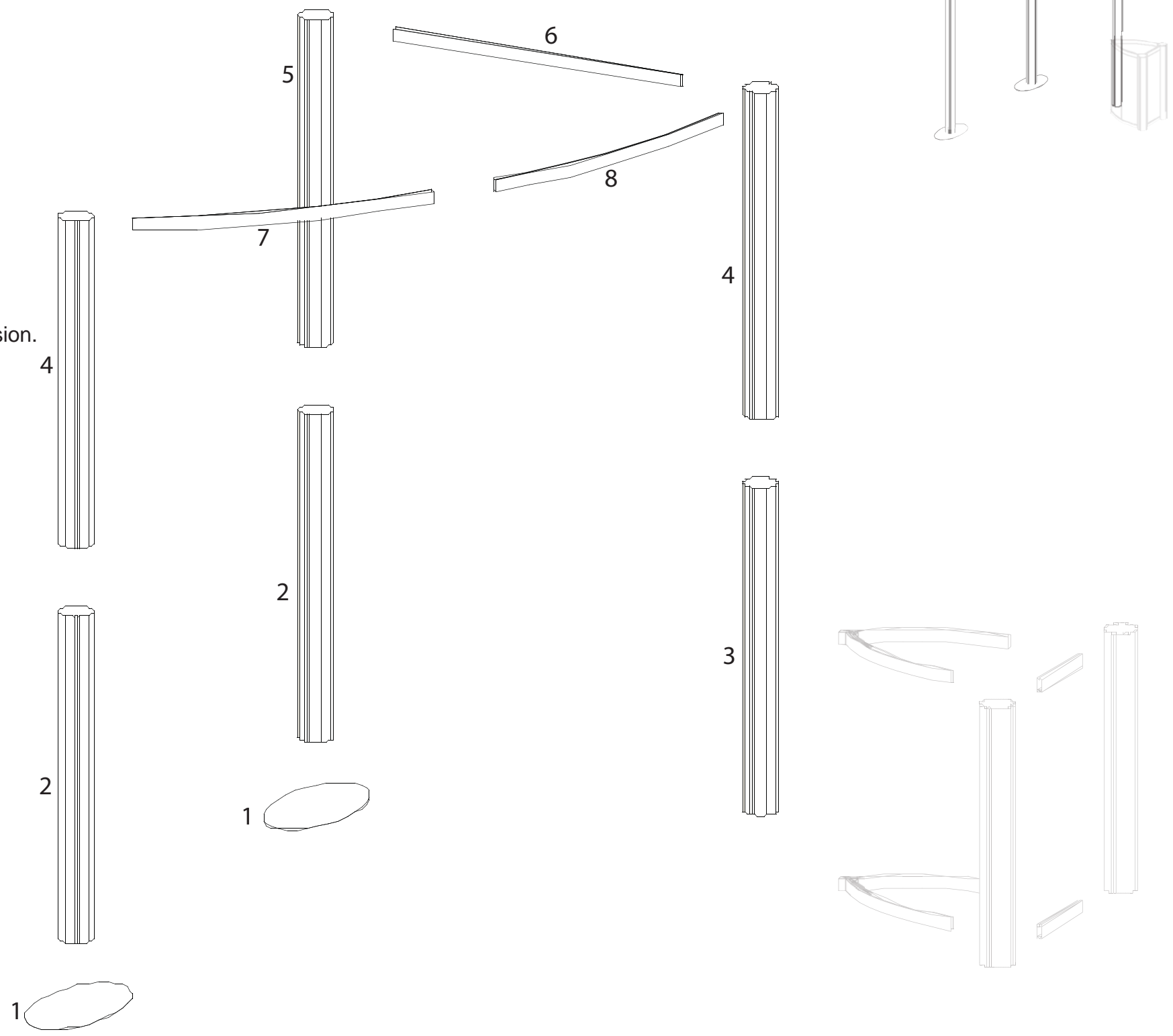

866.652.2100

WHEN DISASSEMBLING ALUMINUM EXTRUSION, TIGHTEN ALL SETSCREWS AND LOCKS TO PREVENT LOSS DURING SHIPPING

866.652.2100

Item	Quantity	Description
15	1	38" Round Vertical Extrusion w/ Door hardware
15A	1	38" Round Vertical Extrusion w/ Door hardware
16	1	12.388" Horizontal Extrusion
17	1	12.388" Horizontal Extrusion
18	1	3-Piece Wishbone
19	1	3-Piece Wishbone
20	2	34.25" Vertical Extrusion

Steps:

- 1) Attach lower 12.388" horizontal extrusion [16] to bottom of 38" round vertical extrusions [15 and 15A].
- 2) Attach lower 3-piece wishbone [18] to bottom of 38" round vertical extrusions [15, 15A and 3 from previous page], as seen at right.
- 3) Attach 34.25" vertical extrusions [20], to 3-piece wishbone [18 and 3], as seen at right.
- 4) Place Inserts and door as shown.
- 5) Attach upper 12.388" horizontal extrusion [17], to top of 38" round vertical extrusions [15].
- 6) Attach upper 3-piece wishbone [19], to top of 38" round vertical extrusions [15, 15A and 3 from previous page], as seen at right.
- 7) Set Internal shelf atop Velcroed supports then place Counter atop assembled Pedestal.

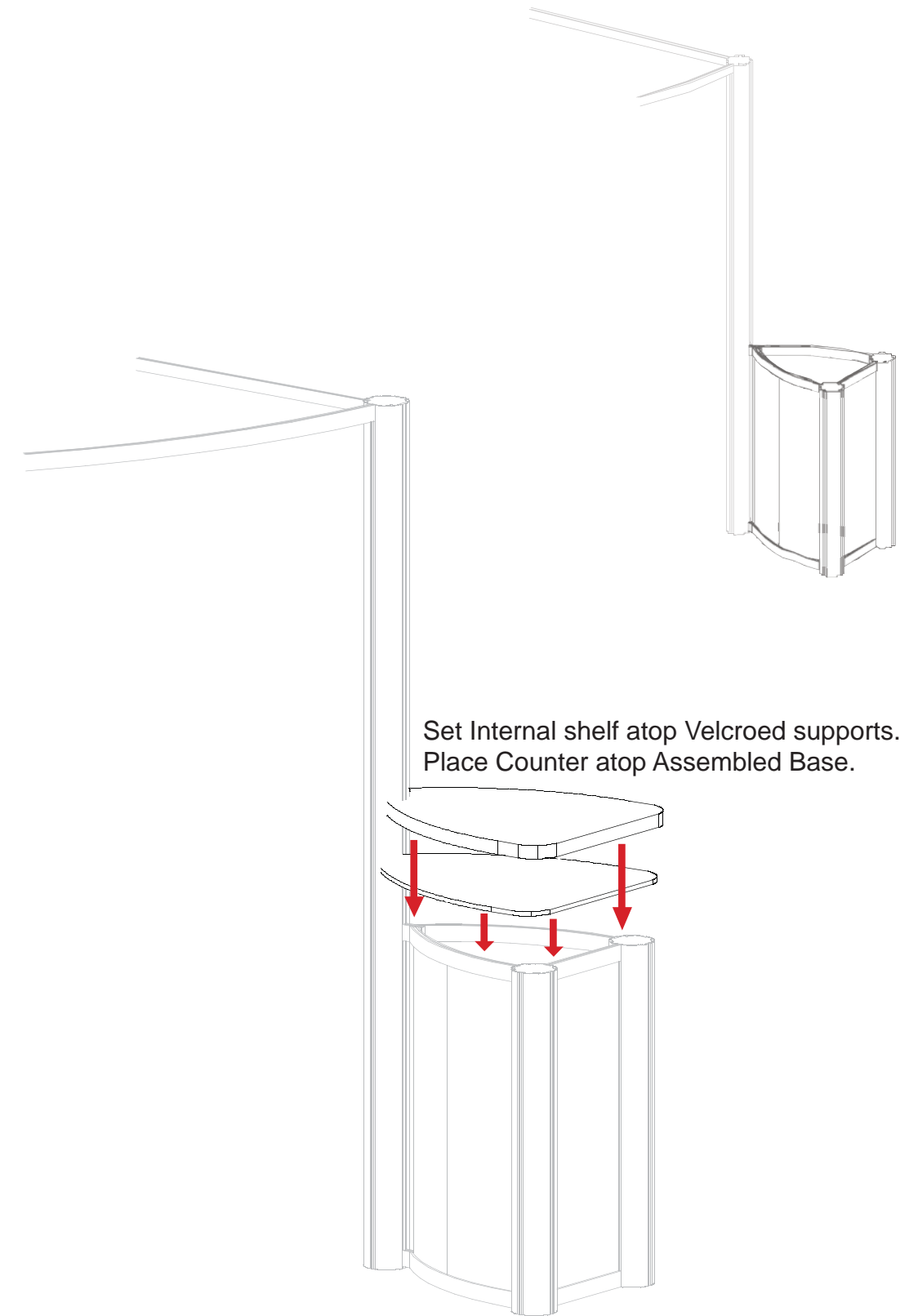
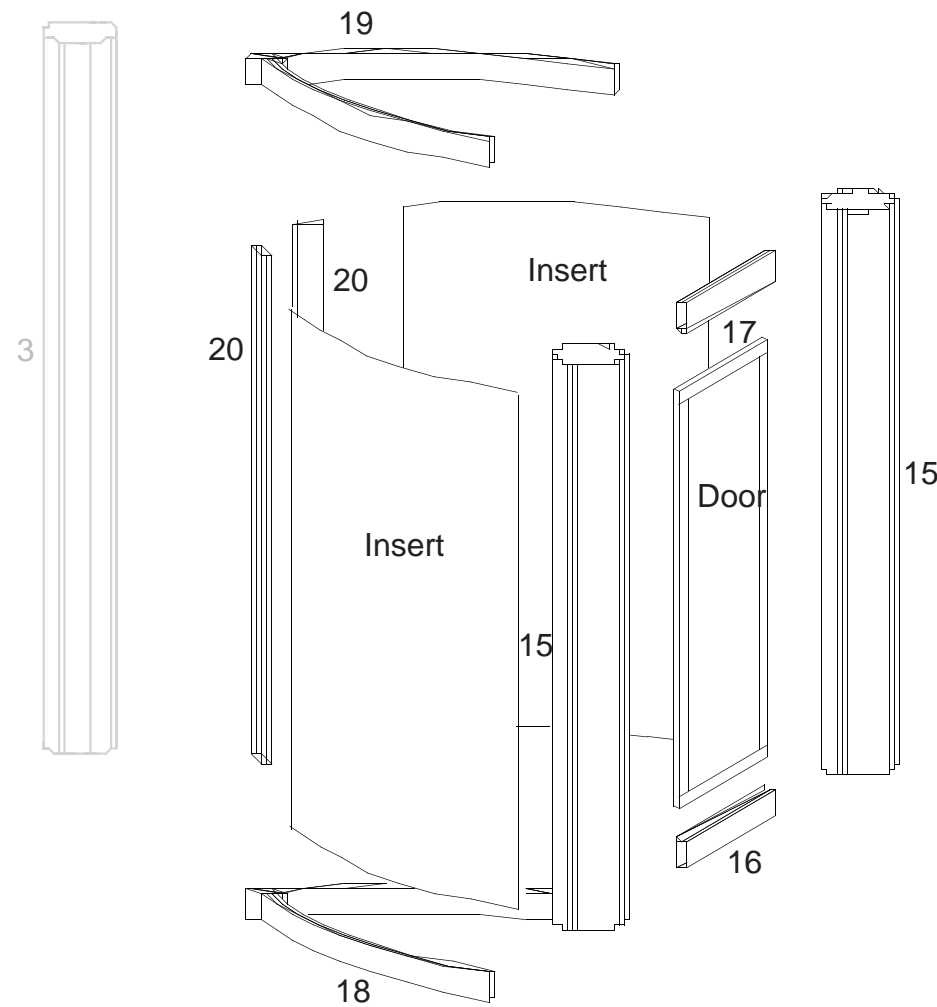

WHEN DISASSEMBLING ALUMINUM EXTRUSION, TIGHTEN ALL SETSCREWS AND LOCKS TO PREVENT LOSS DURING SHIPPING

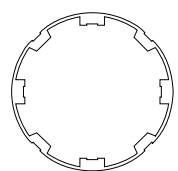

48" h Extrusion

Qty. : 6

Located in Case : _____

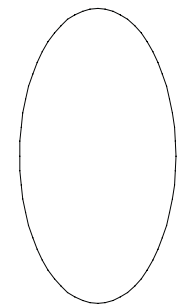

38" h Extrusion

Qty. : 2

Located in Case : _____



42.8205" w Curved Extrusion

Qty. : 2

Located in Case : _____

45" w Extrusion

Qty. : 1

Located in Case : _____

12.388" w Extrusion

Qty. : 2

Located in Case : _____

34.418" w Extrusion

Qty. : 2

Located in Case : _____

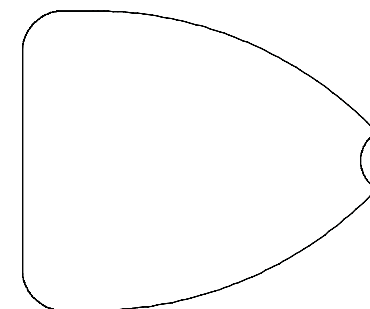

Counter Top

Qty. : 1

Located in Case : _____

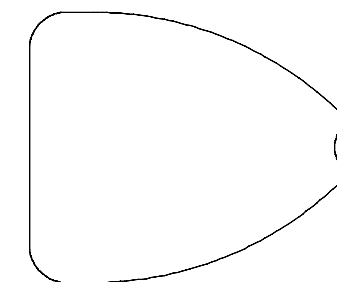

Internal Shelf

Qty. : 1

Located in Case : _____

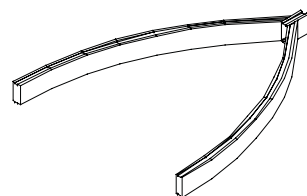

Custom Connector

Qty. : 2

Located in Case : _____



32.5" w x 15" h

Plex Header

Qty. : 2

Located in Case : _____

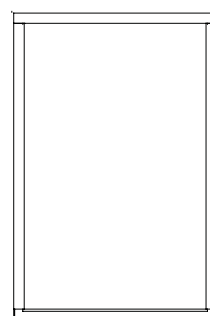

Extrusion Door

Qty. : 1

Located in Case : _____

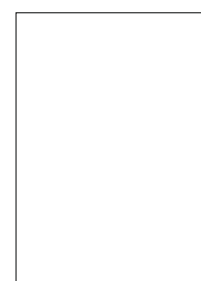

12.888" w x 34.918" h

Laminated Infill

Qty. : 1

Located in Case : _____



21.134" w x 34.918" h

Laminated Infill

Qty. : 2

Located in Case : _____

Additional Accessories:

A10 clips

Located in Case _____

Setup Hardware

Located in Case _____

Monitor Mount

Located in Case _____

Located in Case _____

WHEN DISASSEMBLING ALUMINUM EXTRUSION, TIGHTEN ALL SETSCREWS AND LOCKS TO PREVENT LOSS DURING SHIPPING